

# Mechanical Face Seals

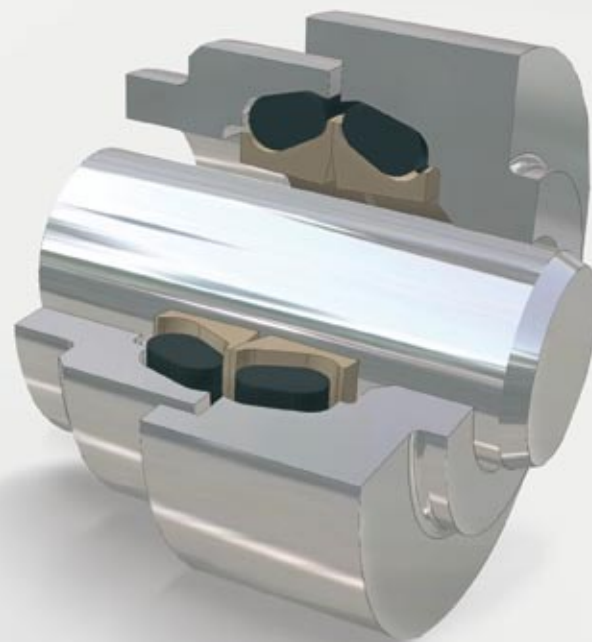

**Your Partner for Sealing Technology**



## Your Partner for Sealing Technology

**Trelleborg Sealing Solutions** is a major international sealing force, uniquely placed to offer dedicated design and development from our market-leading product and material portfolio: a one-stop-shop providing the best in elastomer, thermoplastic, PTFE and composite technologies for applications in aerospace, industrial and automotive industries.

With 50 years of experience, **Trelleborg Sealing Solutions** engineers support customers with design, prototyping, production, test and installation using state-of-the-art design tools. An international network of over 70 facilities worldwide includes 30 manufacturing sites, strategically-positioned research and development centers, including materials and development laboratories and locations specializing in design and applications.

Developing and formulating materials in-house, we utilize the resource of our material database, including over 2,000 proprietary compounds and a range of unique products.

**Trelleborg Sealing Solutions** fulfills challenging service requirements, supplying standard parts in volume or a single custom-manufactured component, through our integrated logistical support, which effectively delivers over 40,000 sealing products to customers worldwide.

Facilities are certified to ISO 9001:2000 and ISO/TS 16949:2002. **Trelleborg Sealing Solutions** is backed by the experiences and resources of one of the world's foremost experts in polymer technology: the **Trelleborg Group**.

ISO 9001:2000

ISO/TS 16949:2002

The information in this brochure is intended to be for general reference purposes only and is not intended to be a specific recommendation for any individual application. The application limits for pressure, temperature, speed and media given are maximum values determined in laboratory conditions. In application, due to the interaction of operating parameters, maximum values may not be achieved. It is vital therefore, that customers satisfy themselves as to the suitability of product and material for each of their individual applications. Any reliance on information is therefore at the user's own risk. In no event will Trelleborg Sealing Solutions be liable for any loss, damage, claim or expense directly or indirectly arising or resulting from the use of any information provided in this brochure. While every effort is made to ensure the accuracy of information contained herewith, Trelleborg Sealing Solutions cannot warrant the accuracy or completeness of information.

**To obtain the best recommendation for a specific application, please contact your local Trelleborg Sealing Solutions marketing company.**

This edition supersedes all previous brochures.  
This brochure or any part of it may not be reproduced without permission.

© All trademarks are the property of Trelleborg Group.  
The turquoise color is a registered trademark of Trelleborg Group.  
© 2009, Trelleborg Group. All rights reserved.



## Contents

Description .....	2
Applications .....	3
Materials .....	4
Design Instructions .....	5
Installation Instructions .....	6
Installation Recommendations for Type DO in Bearing Steel .....	7
Installation Recommendations for Type DO in Cast Iron .....	12
Installation Recommendations for Type DF Bearing Steel .....	15



## ■ Description

**Mechanical Face Seals** are a special form of mechanical seals. They are also known under other designations, such as lifetime seals, floating seals, duo cone seals, toric seals and heavy duty seals.

### Types

There are two different types of **Mechanical Face Seals**: the most common form is Type DO, which is characterized by the use of an **O-Ring** as the secondary sealing element (Figure 1).

Type DF, on the other hand, has an elastomer with a diamond-shaped cross section as a secondary sealing element instead of the **O-Ring** (Figure 2).

Both types consist of two identical metal seal rings which seal against each other on a lapped seal face.

Special designs, like that in Figure 3, are available on request. Seal types can also be divided by the use of different seal materials (see page 4).

### Design Features

The seals consist of two metallic seal rings. They are mounted in separate housing face to face. The elastomeric elements center the seal in the housing.

There are two tapered cones in the housing and at the O.D. of the seal. The taper increases with the depth of the bore due to the different grade of the cones. The housing shape can normally be machined on a NC machine tool.

### Method of Operation

The **O-Ring** and the elastomeric washer provide three different functions:

- They generate a uniform axial face load because of their elasticity.
- They act as a static seal at the inner diameter and outer diameter.
- They prevent the seal ring from turning with the shaft and transmit the torque from the rotating half of the housing through the faces to the static half.

It is important to know that only one half of the seal rotates; the interface between the two precision lapped mating surfaces rotating against the other at right angles to the shaft. They form a leak-proofed seal.

The seal has a wedge shaped gap from the ID to the seal face allowing for easy access to lubricate the seal face. Lubrication is necessary at all times. The lubricant builds a thin film between the sliding faces by a capillary effect and centrifugal force.

The seal face is processed by grinding and lapping.

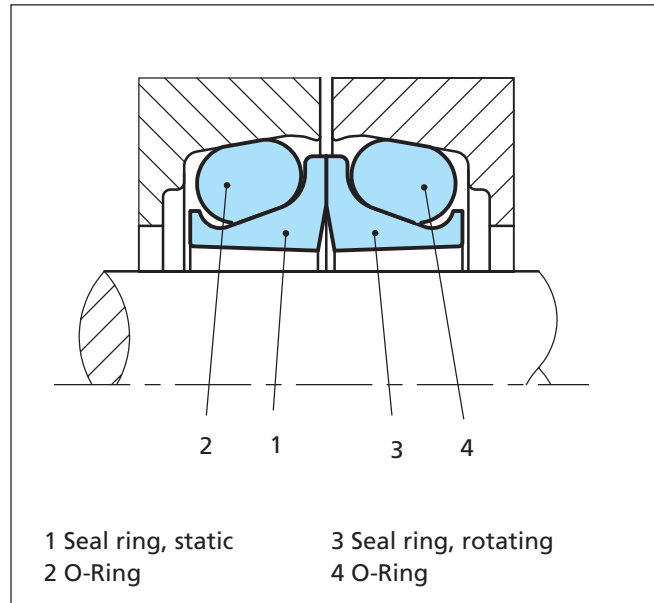

Figure 1 Mechanical Face Seals, Type DO

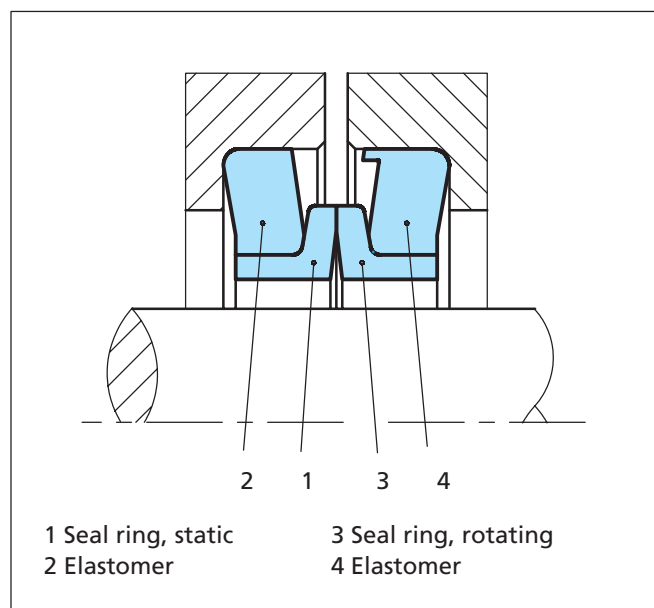

Figure 2 Mechanical Face Seals, Type DF

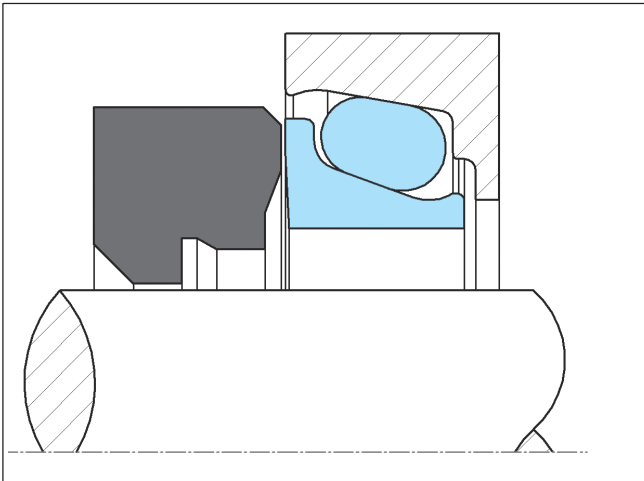

Figure 3 Special Design

### Advantages:

- Simple, reliable design
- High sealing effect against dirt, dust, water and abrasive media from the outside and against oil and grease from the inside
- Cost-effective
- Long service life
- Self-centering to compensate for shaft eccentricity or misalignment
- Maintenance-free
- Easy to assemble

### Applications

Mechanical Face Seals are predominantly used for sealing the bearings in construction machinery or production plants operating under extreme arduous conditions and subject to severe wear.

These include:

- Tracked vehicles, such as excavators and bulldozers
- Conveyor systems
- Heavy trucks
- Axles
- Tunnel boring machines
- Agriculture machines
- Mining machines

Mechanical Face Seals are proven in general machine engineering for gearboxes, mixers, stirrers, wind-driven power stations and other applications with similar conditions or where maintenance-free lifetime time sealing is expected.

### Technical Data

The seals should not be subjected simultaneously to maximum pressure and maximum speed.

Operating Pressure:

The shaft seal is pressure-free under normal operating conditions.

Pressure loading up to max. 0.3 MPa (3 bar) for shell mold Cast Iron and 0.15 MPa (1.5 bar) for material 100Cr6 accepted. A higher static load up to 0.5 MPa (5 bar) is possible.

Internal pressure can lead to misalignment either of the seal or of the O-Ring.

Speed:

Cast Iron:	3 m/s with oil lubrication
100Cr6	2.2 m/s with oil lubrication

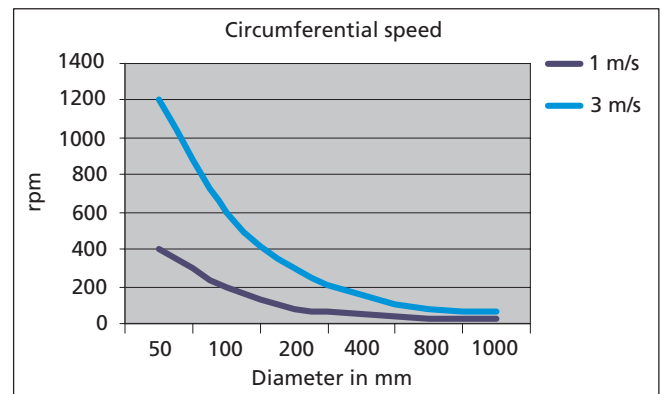

Figure 4 Speed as function of diameter and rpm

Temperature:

-40 °C to +200 °C (-40 °F to +392 °F), depending on the elastomer material.

Lubrication, Media:

The lubrication serves two important functions, therefore it is needed in all cases. It reduces the friction between the seal face and the mating faces, and it acts as a cooling agent for the complete shaft and housing.

The best results with regard to wear and service life are achieved with oil lubrication. Grease lubrication is possible but needs special attention. It can only be used for slower motion. It is sufficient if the oil level is 1/2 to 1/3 of the seal inside diameter. Specially recommended is transmission oil e.g. SAE 80 or SAE 90. In other cases a thinner lubricant can be useful like SAE oils 20W20 or 10W40. The oil level should be between the center line of the shaft and two thirds of seal diameter.

If environmentally compatible bio-oils are to be used, please contact us. In this case, the compatibility of the oil with the elastomer materials used must be tested.



## Materials

### Metal Parts

**Mechanical Face Seals** are available in two different steel grades.

The standard material used for the **Mechanical Face Seals** is a special shell mold Cast Iron. This material was developed specifically for the extreme operating conditions of the seals. The material is a high-alloy, corrosion-resistant Cast Iron. A natural hardness of 58 HRC is achieved directly after casting, which is increased to a minimum of 65 HRC by heat treatment.

The castings are then further processed by grinding, lapping and polishing. For material specifications, see Table I.

Alternatively a cheaper forged roller Bearing Steel (100CR6), material number 1.3505, can also be used. Seals made from this material are manufactured by copy turning followed by induction or salt bath hardening. The hardness is 58 to 63 HRC. The seal faces of these parts are also lapped and polished. For material specifications, see Table I.

**Table I Preferred Materials**

Material Chemical Composition %	Material No. 1.3505	Shell Mold Cast Iron
C	0.90 - 1.05	2.80 - 3.60
Si	0.15 - 0.35	1.00 - 1.60
Mn	0.25 - 0.45	0.40 - 1.00
P	< 0.03	< 0.04
S	< 0.025	< 0.04
Cr	1.40 - 1.65	16.00 - 19.00
Mo	—	2.00 - 4.00
Ni	< 0.30	—
Fe	balance	balance

### Elastomers

Depending on seal type the following standard elastomers are used:

- Type DO - alloy Cast Iron  
Acrylonitrile Butadiene Rubber (NBR)
- Type DO - Bearing Steel (1.3505)  
Acrylonitrile Butadiene Rubber (NBR)

For higher thermal loads or other parameters, different compounds can be supplied.

**Table II Alternative Compounds**

Compound	Hardness	Temperature range
HNBR	60-65 Shore A	-30 °C to 150 °C
FKM	60-65 Shore A	-20 °C to 200 °C
VQM	60-65 Shore A	-50 °C to 200 °C

Please contact your local Trelleborg Sealing Solutions marketing company.

**Table III NBR Compounds**

	Standard NBR Compounds	
Seal Type	Alloy Cast Iron seal	Bearing Steel Seals
Description	NBR	NBR
Hardness	60-65 Shore A	60-65 Shore A
Tensile strength	>12.0	>12.0
Elongation at break	>250	>280
Temperature range*	-30 °C to +100 °C (-22 °F to +212 °F)	-20 °C to +100 °C (-4 °F to +212 °F)

Maximum and minimum operating temperatures depend on specific application criteria and sealing medium.

### Corrosion Test

During operation, **Mechanical Face Seals** can be exposed not only to physical and thermal stresses, but also to extreme environmental stresses.

The behavior and resistance of the material to corrosion is a very important factor; e.g., in contact with seawater or in a maritime climate, when operating in salt plains or on exposure to salt spread on the roads in the winter. **Mechanical Face Seals** must also be able to withstand such conditions. The high-alloy shell mold cast material is particularly suitable to these environments. **Trelleborg Sealing Solutions** has demonstrated this under tough test conditions in salt water.

The surface of seals Bearing Steel 100Cr6 is not as resistant as the alloy materials even if with additional surface treatment a moderate corrosion resistance improvement is achieved.



## ■ Design Instructions

### Seal Housing

The installation dimensions of the seal housing are shown in Table IV and V.

A template can be used to check the housing geometry for Type DO.

The axial gap  $S$  in the housing is such that it meets the demands of the construction machinery industry.

For high sliding speeds it may be necessary to reduce the axial compression, thus reducing the load of the seal faces and the heat generation in the seal face. This is achieved by increasing the axial gap  $S$ .

The following gaps are possible (Table III), depending on the **O-Ring** cross section.

**Table IV Gaps**

O-Ring Cross-Section $d_1$	Gap $S_{max}$
$d_1 < 8.0$	4
$8 \leq d_1 \leq 12.7$	5
$d_1 > 12.7$	6

We recommend that tests be carried out to find the most appropriate setting.

Since the **O-Ring** is always oversized to the housing, the edges of the housing must be rounded.

### Surfaces

Under pressure, elastomers adapt themselves to irregular surfaces. However, for liquid-tight conditions, certain minimum requirements have to be made on the surface finish of the faces to be sealed.

Scores, scratches, pores and concentric or spiral machining scores are not permissible. For the surface of the seal installation chamber we recommend a machining quality of:

$R_a$	< 3.2 $\mu\text{m}$
$R_z$	< 10.0 $\mu\text{m}$
$R_{max}$	< 16.0 $\mu\text{m}$ .

### Shaft

The **Mechanical Face Seal** does not contact the shaft. For this reason, no particular demands have to be met on the hardness or surface finish.

To ensure correct operation a minimum gap must be maintained between the shaft and the inside diameter. This gap serves to supply the seal with lubricant. In order to dissipate the heat of friction, a good exchange of medium must be assured. Furthermore, tolerances, shaft deflections, etc. must be bridged by the gap.

Attention should be paid to the slight geometric deviation between the forged and the cast design. Figure 5 shows a bevel on the cast seal ring typical of the casting process. The forged version, on the other hand, has a cylindrical inner diameter (Figure 6).

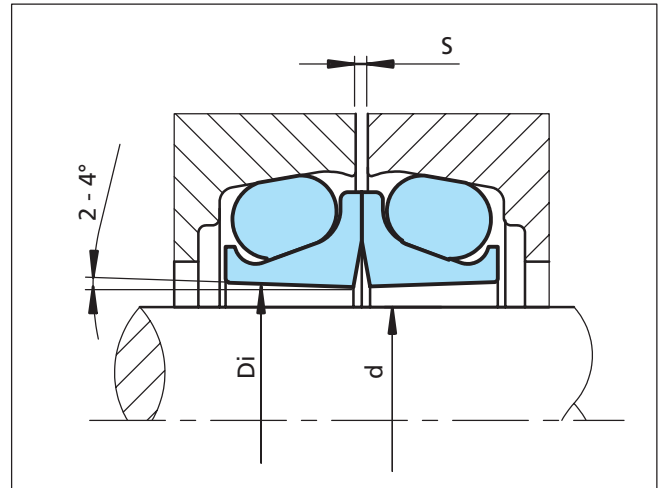

Figure 5 Cast design with inclination at the inside diameter

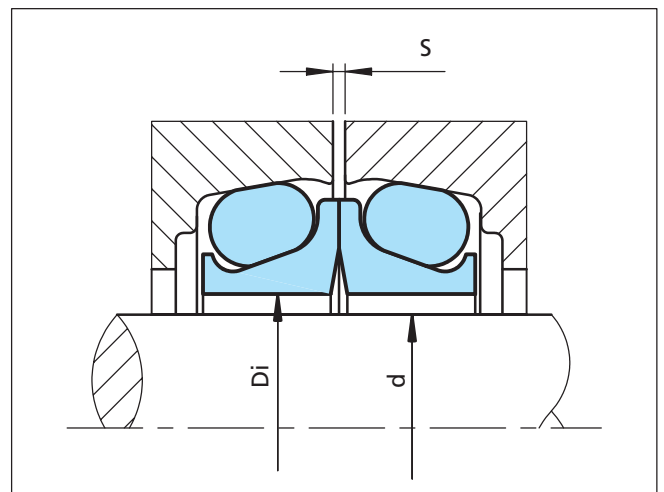

Figure 6 Roller Bearing Steel design with smooth and cylindrical treatment at the inside diameter



## ■ Installation Instructions

### Preparation for Installation

**Mechanical Face Seal** must be installed with great care. Damage to the precision lapped seal faces must be avoided at all costs. The installation location must be kept free from dust and dirt.

The installation should be carried out in the following steps.

### Preparation before Installation

- Remove the seal from its packing only immediately before installation.
- Do not stand the seal on the lapped surface.
- Coat the seal face with a thin film of oil using clean oil and a lint-free cloth, e.g. chamois leather.
- Check that the housing is free of nick or burr on installation radii.
- Check if **O-Ring** or washer is properly placed back on the seal. The **O-Ring** must be seated in the outer radius (Type DO) inside the retaining lip.

### Installation Instructions for the Type DO

- Make sure that the **O-Ring** is not twisted. A twisted **O-Ring** may cause a looped effect.
- Installation, particularly of large **O-Rings**, requires a great deal of force. We recommend that the **O-Ring** be coated with lubricant (soapy water, water/spirits mixture or an oil film) before installation.
- Assemble the two halves of the seal in the housing by using an installation tool. Center the **O-Ring** in the housing. Use two hands on the tool to press the seal into the housing with a firm push.
- Check if the tool is touching the housing all around the circumference.
- Remove the tool and make a visual check for position of **O-Ring** and seal. Make sure that everything is seated symmetrically.
- Clean both seal faces with denatured alcohol and apply a thin film of clean oil to the faces.
- Tilt the two parts together bringing the slide faces carefully into contact.
- Adjust the gap S.
- Fill the housing with oil and bleed, if necessary.

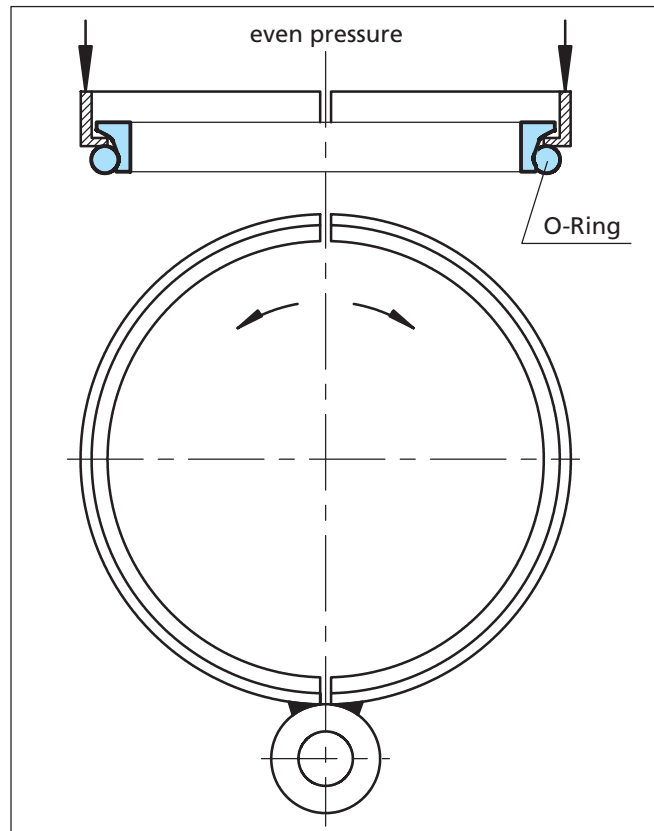

Figure 7 Fitting Tool

In the event that the installation tool cannot be withdrawn or where the seal is of a special design, an installation **O-Ring** can be used. The installation **O-Ring** is placed between the **O-Ring** of the seal and rear of the ramp on the Seal Ring. As force is applied to the Seal Ring during installation, the installation **O-Ring** backs up the **O-Ring** and will not allow it to roll up the ramp. After installation the **O-Ring** is easily removed- (see Figure 8).

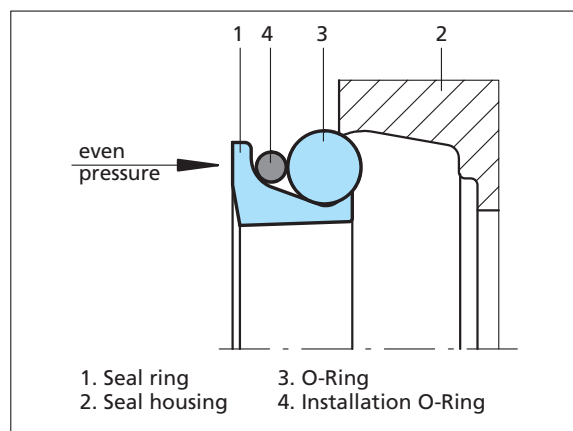

Figure 8 O-Ring as installation aid



## ■ Installation Recommendations for Type DO in Bearing Steel

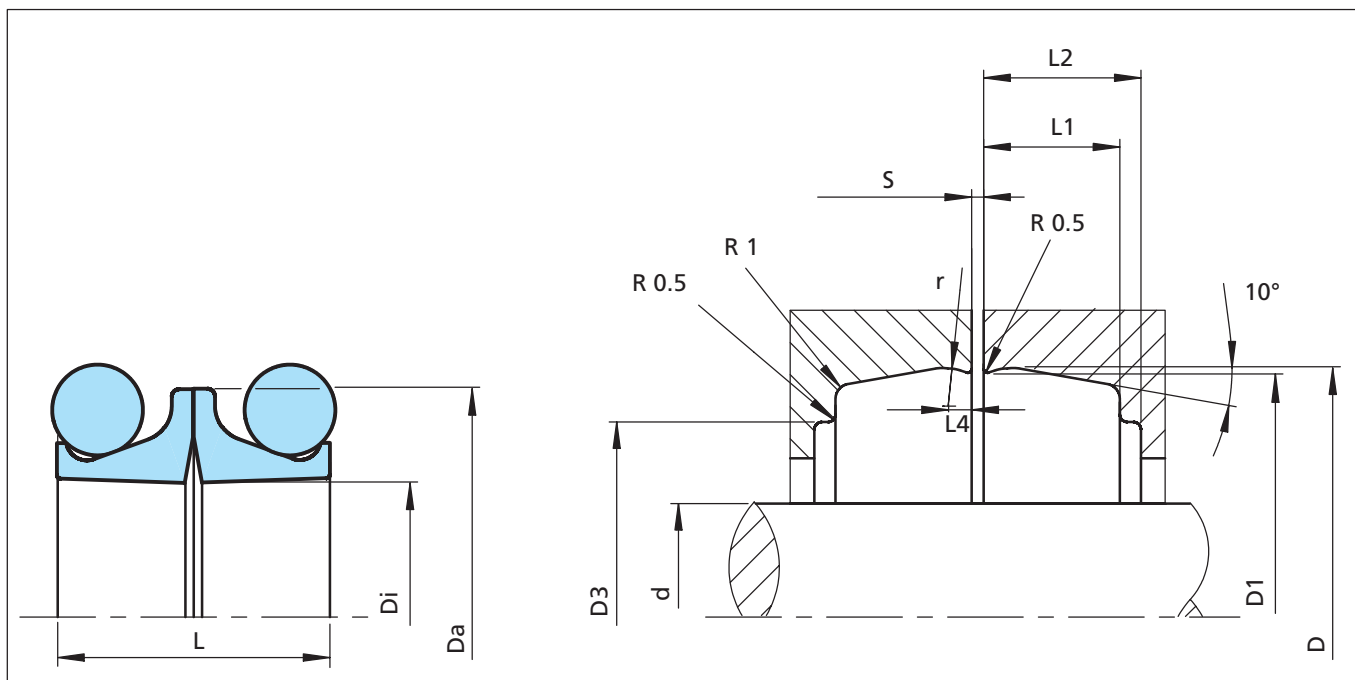

Figure 9 Installation Drawing

Table V Installation Dimensions

TSS Part No.	GNL	$D_i$	$D_a$	L	$d_{max.}$	$D_{\pm 0.1}$	$D_1 \pm 0.1$	$D_3$	$L_1$	$L_2$ min.	$L_4$	r	S
TLDOA0340	5201	34.0	45.0	14.0	30.0	47.0	46.5	42.0	6.5	8.0	1.0	1.0	1.5
TLDOC0380	4301	38.0	51.0	20.4	35.0	53.7	53.0	46.0	9.0	11.0	1.8	2.0	3.0
TLDOA0390	5211	39.0	50.0	14.0	35.0	52.0	51.5	46.0	6.5	8.0	1.0	1.0	1.5
TLDOA0400 <sup>2)</sup>	4701	40.0	52.0	20.0	36.0	55.0	54.2	46.0	9.0	11.0	1.0	1.0	3.0
TLDOA0430	4961	43.0	58.0	24.0	39.0	61.6	60.8	53.4	10.0	12.0	1.8	2.5	3.0
TLDOB0450	4821	45.0	58.0	21.6	41.0	61.6	61.0	54.0	10.5	12.5	1.8	2.5	3.0
TLDOA0460 <sup>1)</sup>	4201	46.0	59.0	20.0	42.0	61.6	61.2	53.0	9.0	11.0	2.0	2.5	3.0
TLDOB0480	5241	48.0	58.0	14.4	44.0	59.9	59.4	55.0	6.3	8.0	1.5	1.7	1.5
TLDOC0480	5751	48.0	62.0	26.0	45.0	68.0	67.2	58.0	12.0	14.0	2.0	3.0	3.0
TLDOA0555	0496	55.5	70.0	22.0	52.0	73.8	73.1	65.5	10.0	11.5	2.4	5.0	3.0
TLDOB0560	5741	56.0	70.0	26.0	53.0	76.0	75.2	66.0	12.0	14.0	2.0	2.5	3.0
TLDOA0570	3786	57.0	77.5	35.6	54.0	81.4	80.7	68.5	15.2	20.9	3.5	4.8	
TLDOB0580	4851	58.0	75.0	27.0	53.0	79.2	78.6	66.0	12.0	14.0	2.0	2.5	3.0
TLDOA0600 <sup>1)</sup>	4321	60.0	74.0	20.6	57.0	78.4	77.4	70.0	9.0	11.0	1.9	2.5	3.0
TLDOB0610	0441	61.0	73.0	17.6	58.0	75.8	75.5	66.8	6.5	7.5	1.0	1.4	3.0
TLDOB0635	3108	63.5	82.5	31.8	60.5	86.5	85.7	73.5	15.2	16.8	3.5	4.8	3.0
TLDOA0640 <sup>1)</sup>	5681	64.0	78.0	25.0	61.0	84.6	83.8	74.0	12.5	14.5	2.0	3.0	3.0
TLDOA0675	5591	67.5	86.5	31.8	64.0	91.0	90.0	78.0	14.5	17.0	2.8	5.0	3.0

Missing values on request <sup>1)</sup>  $\alpha=12^\circ$  <sup>2)</sup>  $\alpha=15^\circ$



## Mechanical Face Seals

TSS Part No.	GNL	D <sub>i</sub>	D <sub>a</sub>	L	d <sub>max.</sub>	D±0.1	D <sub>1</sub> ±0.1	D <sub>3</sub>	L <sub>1</sub>	L <sub>2</sub> min.	L <sub>4</sub>	r	S
TLDOA0690 <sup>1)</sup>	5631	69.0	84.0	24.0	66.0	89.6	88.6	78.5	11.0	13.0	1.9	3.0	3.0
TLDOB0690	5851	69.0	89.0	24.0	66.0	92.5	91.5	83.0	11.0	13.5	2.8	5.0	3.0
TLDOB0700	4871	70.0	90.0	29.0	65.0	95.5	94.7	84.0	13.5	15.5	2.0	3.0	3.0
TLDOB0710	5841	71.0	84.0	20.0	68.0	87.4	86.7	80.8	8.5	10.0	1.8	2.0	3.0
TLDOA0725	3751	72.5	92.0	35.6	70.1	96.0	95.2	83.0	15.2	20.9	3.5	4.8	
TLDOB0730	5611	73.0	92.0	31.8	70.0	96.2	95.4	84.0	15.0	17.0	2.8	4.0	3.0
TLDOA0731	3308	73.1	91.9	31.8	70.1	96.0	95.2	83.0	15.2	16.8	3.5	4.8	3.0
TLDOA0735	5481	73.5	88.5	20.4	70.0	90.2	89.4	82.0	12.7	14.3	2.2	2.8	3.0
TLDOB0740	4896	74.0	86.5	22.5	70.0	91.4	90.7	80.0	9.5	11.5	2.0	3.0	3.0
TLDOA0750	4901	75.0	94.0	29.0	73.0	101.4	100.6	89.0	14.5	16.5	2.0	3.0	3.0
TLDOA0775 <sup>2)</sup>	3768	77.5	87.6	13.6	75.9	90.7	90.2	89.5	7.5	8.0	1.4	1.5	
TLDOA0795	5891	79.5	92.5	20.0	76.0	96.0	95.3	88.0	8.5	10.5	1.8	2.0	3.0
TLDOB0800	4931	80.0	100.0	30.0	76.0	104.1	103.3	93.0	15.0	18.0	2.3	2.5	3.0
TLDOA0810	5826	81.0	98.0	28.0	78.0	102.3	101.3	91.0	12.5	14.5	2.8	5.0	3.0
TLDOA0825	3771	82.5	102.0	35.6	80.5	107.3	106.5	94.3	15.2	20.9	3.5	4.8	
TLDOB0900	3711	90.0	105.0	26.0	87.4	107.3	106.7	100.4	11.5	14.0	2.9	2.8	3.0
TLDOC0900 <sup>1)</sup>	5671	90.0	109.0	32.0	86.0	112.5	111.7	104.0	14.5	17.0	3.2	3.0	3.0
TLDOA0904	3504	90.4	109.4	31.8	87.4	113.4	112.7	100.4	15.2	16.8	3.5	4.8	3.0
TLDOB0904	3743	90.4	109.5	35.6	88.5	113.4	112.7	100.4	15.2	20.9	3.5	4.8	
TLDOB0920	4886	92.0	109.5	22.0	88.0	113.8	113.0	105.0	9.5	11.5	2.0	3.0	3.0
TLDOB0940	4946	94.0	106.5	23.0	90.0	111.6	110.8	102.0	9.5	11.5	2.0	3.0	3.0
TLDOA0950	0181	95.0	111.0	24.0	92.0	115.6	114.8	108.0	11.0	12.5	1.8	2.0	3.0
TLDOC0950 <sup>1)</sup>	5701	95.0	114.0	32.0	91.0	120.0	119.2	107.0	15.0	17.0	2.5	3.0	3.0
TLDOA0965 <sup>2)</sup>	3761	96.5	106.8	13.6	94.9	109.7	109.2	108.5	7.5	8.0	1.4	1.5	3.0
TLDOA1000	3607	100.0	119.0	31.8	97.0	123.0	122.2	110.0	15.2	16.8	3.5	4.8	3.0
TLDOA1030 <sup>1)</sup>	1801	103.0	122.0	32.0	99.0	127.2	126.2	115.0	15.5	17.5	2.5	3.0	3.0
TLDOD1040	4866	104.0	117.0	22.0	100.0	121.0	120.2	107.0	9.5	11.5	2.0	3.0	3.0
TLDOE1040	4856	104.0	122.5	22.5	100.0	125.5	125.1	117.5	9.5	11.5	2.0	3.0	3.0
TLDOF1040	8001	104.0	125.0	28.0	100.0	128.5	127.5	117.0	12.5	14.0	2.8	5.0	3.0
TLDOA1070	0486	107.0	125.0	24.0	103.0	130.4	129.4	119.5	11.0	13.5	2.8	5.0	3.0
TLDOA1090	4841	109.0	132.0	32.0	104.0	136.5	135.5	124.0	15.5	17.5	2.5	3.0	3.0
TLDOB1100 <sup>1)</sup>	5501	110.0	128.0	32.0	106.0	133.0	132.0	121.0	14.5	17.0	2.5	3.0	3.0
TLDOB1110	5443	111.0	128.0	22.0	107.0	132.5	132.0	123.0	10.6	12.3	2.8	3.0	3.0
TLDOA1110	0290	111.0	133.0	32.0	108.0	137.0	136.5	124.5	14.5	18.0	2.8	5.0	5.0
TLDOA1145	0179	114.5	129.0	23.5	107.5	134.1	133.1	126.0	10.4	11.9	2.8	5.0	3.0
TLDOA1150	4881	115.0	137.0	31.0	110.0	141.8	140.8	130.0	14.5	16.5	2.5	3.0	3.0
TLDOA1170	5816	117.0	138.0	31.8	114.0	142.5	141.5	132.0	14.5	17.0	2.8	5.0	3.0
TLDOB1170	5801	117.0	140.0	28.0	113.0	142.5	141.5	132.0	12.5	14.0	2.8	5.0	3.0
TLDOA1190	5361	119.0	140.0	28.0	115.0	142.5	141.5	132.0	12.5	14.0	2.8	5.0	3.0
TLDOA1200	4711	120.0	139.0	31.8	115.0	143.0	142.0	129.3	14.3	17.4	3.0	5.4	3.0
TLDOC1200	5461	120.0	141.0	31.8	117.0	144.0	143.0	138.0	14.5	17.5	2.8	5.0	3.0

Missing values on request <sup>1)</sup> α=12° <sup>2)</sup> α=15°



TSS Part No.	GNL	D <sub>i</sub>	D <sub>a</sub>	L	d <sub>max.</sub>	D±0.1	D <sub>1</sub> ±0.1	D <sub>3</sub>	L <sub>1</sub>	L <sub>2</sub> min.	L <sub>4</sub>	r	S
TLDOD1200	5641	120.0	142.0	38.0	116.0	149.0	148.0	133.0	17.0	19.0	2.5	3.0	4.0
TLDOA1240	4926	124.0	141.0	22.0	120.0	146.4	145.3	136.0	10.6	12.3	2.8	3.0	3.0
TLDOB1250	4221	125.0	144.1	31.8	120.0	148.5	147.5	136.0	14.3	17.4	3.0	5.0	3.0
TLDOA1260	3516	126.0	146.0	31.8	123.0	150.0	149.2	137.0	15.2	16.8	3.5	4.8	3.0
TLDOA1265	5539	126.5	139.0	26.8	123.5	143.8	143.1	136.9	11.8	14.2	2.9	2.8	3.0
TLDOC1270	0451	127.0	141.0	29.0	124.0	144.0	143.0	136.0	12.0	14.5	2.8	5.0	3.0
TLDOD1270	3851	127.0	141.2	25.4	124.0	143.8	143.1	136.9	11.8	14.2	2.9	2.8	3.0
TLDOA1270	3701	127.0	146.0	31.8	124.0	150.5	149.5	138.0	14.5	17.5	2.8	5.0	4.0
TLDOB1300	4911	130.0	150.5	32.0	125.0	155.6	154.6	144.0	14.5	16.5	2.5	5.0	3.0
TLDOD1300	5731	130.0	152.0	38.5	125.0	159.0	158.0	144.0	18.5	20.5	2.5	3.0	
TLDOA1427	3841	142.7	156.9	25.4	139.7	159.7	158.9	152.1	11.8	14.2	2.9	2.8	3.0
TLDOB1430	5451	143.0	160.0	27.0	138.0	164.0	163.0	154.0	12.0	14.5	2.8	5.0	4.0
TLDOA1440	0276	144.0	157.0	26.0	140.0	160.0	159.0	154.5	12.0	14.5	2.8	5.0	3.0
TLDOB1460	5596	146.0	168.0	38.0	143.0	176.8	175.9	159.0	18.0	20.5	3.0	6.5	4.0
TLDOC1460	5101	146.0	175.0	38.0	142.0	180.5	179.5	162.0	17.7	20.5	3.0	6.3	6.0
TLDOA1463	3121	146.3	171.7	38.0	143.3	176.8	175.9	158.9	18.4	20.3	3.7	6.3	
TLDOA1470	5541	147.0	167.0	28.0	142.0	171.0	170.0	160.0	13.0	15.5	2.8	5.0	3.0
TLDOA1480	4811	148.0	170.0	31.0	142.0	175.6	174.6	164.0	15.0	17.0	2.5	3.0	4.0
TLDOC1500	5621	150.0	172.0	40.0	147.0	179.0	178.0	165.0	18.0	20.0	2.5	2.0	4.0
TLDOA1520	4351	152.0	171.5	32.0	149.0	175.4	174.7	162.5	15.2	16.8	3.5	4.8	
TLDOA1530	0436	153.0	171.5	28.0	149.0	176.3	175.3	164.5	12.5	14.5	2.8	5.0	3.0
TLDOA1539	3831	153.9	168.1	25.4	150.9	171.0	170.2	164.0	11.8	14.2	2.9	2.8	3.0
TLDOA1540	0446	154.0	168.0	27.0	150.0	171.0	170.0	162.5	12.0	14.5	2.3	3.0	3.0
TLDOD1540	0491	154.0	169.0	22.0	150.0	174.5	173.5	166.0	9.2	11.0	2.3	3.0	3.0
TLDOE1540	0426	154.0	170.0	21.0	150.0	175.1	174.1	167.0	9.2	10.0	2.3	3.0	3.0
TLDOC1540	0476	154.0	173.5	32.0	151.0	178.0	177.0	166.0	14.5	17.0	2.8	6.5	3.0
TLDOA1633	3243	163.3	191.2	38.0	160.3	196.8	195.8	178.9	18.4	20.3	3.7	6.3	6.0
TLDOB1633	3221	163.3	191.3	46.0	160.0	196.8	195.9	178.9	18.4	24.1	3.7	6.3	6.0
TLDOA1640	0471	164.0	189.0	30.0	160.0	193.5	192.5	179.0	14.5	17.0	2.8	5.0	3.0
TLDOA1650	5871	165.0	181.0	27.0	161.0	185.0	184.0	176.5	12.0	14.5	2.7	4.0	3.0
TLDOA1725	5531	172.5	190.0	25.4	168.0	192.7	191.8	188.0	12.7	14.3	2.3	2.8	3.0
TLDOA1740	5546	174.0	190.0	25.4	170.0	192.7	191.8	188.0	12.7	14.3	2.3	2.8	3.0
TLDOA1770	0401	177.0	200.0	31.0	173.0	204.5	203.4	191.0	14.5	17.0	3.1	5.0	3.0
TLDOA1780	5866	178.0	199.0	32.0	175.0	203.6	202.4	190.0	23.0	16.0	3.0	5.0	3.0
TLDOB1780	5711	178.0	200.0	38.0	175.0	210.6	209.6	192.0	19.0	21.0	3.0	4.0	4.0
TLDOA1800	5526	180.0	197.4	21.4	173.0	202.2	201.9	196.0	9.4	10.6	1.2	3.0	3.0
TLDOA1823	3261	182.3	210.3	38.0	179.3	215.4	214.4	197.5	18.4	20.3	3.7	6.3	6.0
TLDOA1824	3209	182.4	210.3	46.0	179.0	215.4	214.4	197.5	18.4	24.1	3.7	6.3	6.0
TLDOB1830	0201	183.0	202.0	28.0	179.0	206.0	205.0	195.0	12.5	14.5	2.8	5.0	3.0
TLDOA1860	5131	186.0	203.0	25.4	182.0	205.7	204.9	190.5	14.5	16.0	2.3	2.8	3.0
TLDOA1910	5856	191.0	210.0	28.0	187.0	214.0	213.0	203.0	12.5	14.5	2.8	5.0	3.0

Missing values on request <sup>1)</sup> α=12° <sup>2)</sup> α=15°



## Mechanical Face Seals

TSS Part No.	GNL	D <sub>i</sub>	D <sub>a</sub>	L	d <sub>max.</sub>	D±0.1	D <sub>1</sub> ±0.1	D <sub>3</sub>	L <sub>1</sub>	L <sub>2</sub> min.	L <sub>4</sub>	r	S
TLDOA1920	5421	192.0	215.0	33.0	189.0	220.8	219.8	207.0	16.5	18.5	3.0	4.0	4.0
TLDOA1950	0188	195.0	216.5	32.0	191.0	221.0	220.0	207.0	14.5	17.0	2.8	5.0	3.0
TLDOA2000	5111	200.0	228.5	38.0	196.0	233.5	232.5	215.5	18.0	20.5	3.1	6.3	6.0
TLDOA2020	3871	202.0	222.3	26.5	197.0	224.9	224.1	217.9	11.8	14.2	2.9	2.8	3.0
TLDOA2050	5821	205.0	227.0	30.0	198.0	231.5	230.5	219.0	14.5	17.0	2.8	5.0	3.0
TLDOA2090	5651	209.0	234.0	42.0	206.0	242.6	241.6	224.0	19.5	22.5	3.0	4.0	4.0
TLDOA2200	5881	220.0	239.5	32.0	215.0	244.0	243.0	232.0	14.5	16.5	2.8	5.0	3.0
TLDOC2235	3320	223.5	251.5	46.0	220.0	256.6	255.7	238.7	18.4	24.1	3.7	6.3	6.0
TLDOA2240	3345	223.5	251.4	38.0	220.5	256.5	255.7	238.7	18.4	20.3	3.7	6.3	6.0
TLDOA2250	4831	225.0	252.0	38.0	220.0	258.0	257.0	241.0	19.0	21.0	3.0	4.0	4.0
TLDOA2316	3861	231.6	259.6	38.0	228.0	264.7	263.8	247.0	18.4	20.5	3.7	6.3	6.0
TLDOA2380	0176	238.0	261.0	32.0	231.0	265.5	264.5	254.0	14.5	17.0	2.8	5.0	3.0
TLDOA2390	4861	239.0	268.0	40.0	234.0	274.2	273.2	257.0	20.5	22.5	3.0	4.0	4.0
TLDOC2400	0411	240.0	262.8	38.0	236.0	273.5	272.5	255.5	18.0	20.5	3.1	6.5	3.0
TLDOA2450	0161	245.0	264.5	32.0	238.0	268.9	267.9	255.0	14.5	17.0	2.8	5.0	3.0
TLDOB2500	5721	250.0	276.0	44.0	247.0	284.6	283.6	266.0	20.5	24.0	3.0	4.0	4.0
TLDOA2520	5811	252.0	280.0	38.0	248.0	285.5	284.5	265.0	18.0	20.0	3.1	6.5	3.0
TLDOB2650	3526	265.0	292.8	46.0	261.0	297.8	297.0	280.0	18.4	24.1	3.7	6.3	6.0
TLDOA2650	3519	265.0	293.0	38.0	261.0	298.0	297.0	280.0	18.0	20.5	3.1	6.3	4.0
TLDOA2750	5846	275.0	303.0	38.0	271.0	308.0	307.0	290.0	18.0	20.5	3.1	6.5	3.0
TLDOA2829	3777	282.9	310.8	38.0	280.0	316.3	315.4	298.4	18.4	20.3	3.7	6.3	6.0
TLDOA3000	5831	300.0	325.0	38.0	296.0	335.5	334.5	318.0	17.5	20.5	3.1	6.5	3.0
TLDOB3000	4891	300.0	328.0	40.0	295.0	333.0	332.0	315.0	18.5	21.0	3.0	4.0	4.0
TLDOA3010	3780	301.0	328.0	38.0	297.0	333.0	332.1	315.1	18.4	20.3	3.7	6.3	6.0
TLDOA3180	0166	318.0	341.0	38.0	315.0	351.5	350.5	334.0	18.0	20.5	3.1	6.5	3.0
TLDOA3185	3622	318.5	346.4	38.0	315.5	351.6	350.7	333.7	18.4	20.3	3.7	6.3	6.0
TLDOA3190	3619	319.0	346.5	46.0	315.0	351.6	350.7	333.7	18.4	24.1	3.7	6.3	6.0
TLDOA3395	4921	339.5	369.0	40.0	335.0	374.8	373.8	358.0	19.0	21.5	3.0	4.0	4.0
TLDOA3400	0171	340.0	368.0	40.0	337.0	374.8	373.8	358.0	19.0	21.5	3.0	4.0	3.0
TLDOA3500	5861	350.0	375.0	38.0	345.0	385.0	384.5	368.0	17.5	20.5	3.1	6.5	3.0
TLDOC3665	3801	366.5	394.4	38.0	363.5	399.5	398.6	381.7	18.4	20.3	3.7	6.3	6.0
TLDOD3665	3981	366.5	394.5	48.0	363.5	399.5	398.6	381.7	18.4	24.1	3.7	6.3	6.0
TLDOA3672	3844	367.2	394.5	38.0	364.2	399.5	398.6	381.7	18.4	20.3	3.7	6.3	6.0
TLDOA3700	5141	370.0	398.0	38.0	365.0	403.5	402.6	385.0	17.5	20.5	3.0	6.5	3.0
TLDOA3805	4966	380.5	405.0	40.0	375.0	412.2	410.5	395.0	17.0	22.0	3.0	4.0	4.0
TLDOA3870	5896	387.0	415.0	38.0	382.0	420.3	419.3	402.0	17.5	20.5	3.1	6.5	3.0
TLDOA4285	5761	428.5	454.0	37.0	425.0	462.3	461.3	444.6	18.5	21.0	3.0	4.0	4.0
TLDOA4292	3811	429.2	457.2	38.0	426.2	462.3	461.4	444.4	18.4	20.3	3.7	6.3	6.0
TLDOA4700	0461	470.0	500.0	50.0	465.0	512.2	510.2	490.0	23.5	25.5	13.0	6.0	3.0
TLDOA5054	3821	505.4	533.4	44.0	502.4	538.5	537.6	520.6	21.3	26.2	3.7	6.3	6.0
TLDOA5300	5878	530.0	560.0	50.0	524.0	572.2	570.2	545.0	23.5	25.5	4.0	6.0	3.0

Missing values on request <sup>1)</sup> α=12° <sup>2)</sup> α=15°



TSS Part No.	GNL	D <sub>i</sub>	D <sub>a</sub>	L	d <sub>max.</sub>	D±0.1	D <sub>1</sub> ±0.1	D <sub>3</sub>	L <sub>1</sub>	L <sub>2</sub> min.	L <sub>4</sub>	r	S
TLDOA5800	0421	580.0	608.0	43.6	575.5	613.0	611.0	596.0	19.7	21.7	4.0	6.5	6.0
TLDOA5910	0456	591.0	623.0	50.0	585.0	635.2	632.1	613.0	23.5	25.5	4.0	6.0	5.0
TLDOA6670	3876	667.0	700.0	44.0	660.0	705.6	704.6	687.6	18.4	23.4	3.7	6.3	6.0
TLDOA7100	0431	710.0	750.0	50.0	700.0	762.2	760.2	740.0	23.5	25.5	4.0	6.0	3.0
TLDOA8300	5836	830.0	886.0	80.0	815.0	891.6	890.6	860.0	34.5	39.5	4.4	10.0	17.0

Missing values on request <sup>1)</sup> α=12° <sup>2)</sup> α=15°

## Ordering Example

Mechanical Face Seal Type DO in Bearing Steel

Inside diameter D<sub>i</sub> = 125.0 mm

Materials: Seal rings of Bearing Steel (1.3505)  
O-Rings of NBR

TSS Article No.	TLDOA1250 - 2CP00
TSS Part No.	
Inside Ø x 10	
Quality Index (Standard)	
Material No.	

Dimensions and Part-Number see Table V, page 7.  
Materials see page 4.



## Installation Recommendations for Type DO in Cast Iron

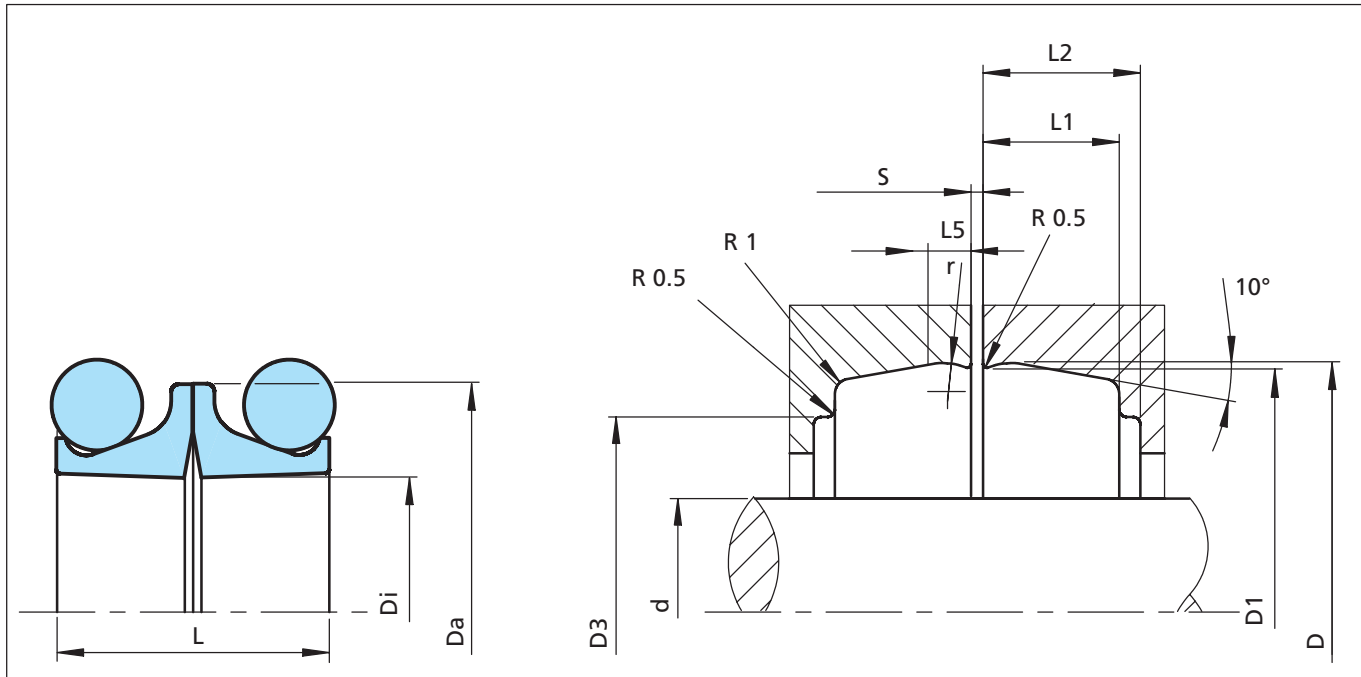

Figure 10 Installation Drawing

Table VI Installation Dimensions

TSS Part No.	$D_i$	$D_a$	L	$d_{max.}$	$D \pm 0.1$	$D_1 \pm 0.1$	$D_3$	$L_1$	$L_2$ min.	$L_5$	r	S
TLDOA0380	38.0	51.0	20.0	35.0	53.7	53.0	46.0	9.0	11.0	1.6	2.0	3.0
TLDOA0430	43.0	58.0	24.0	40.0	62.0	61.3	51.0	10.5	12.5	2.0	2.0	3.0
TLDOA0450	45.0	58.0	21.0	42.0	61.6	60.8	53.4	10.0	12.0	1.8	2.5	3.0
TLDOA0480	48.0	62.0	25.0	45.0	68.0	67.2	58.0	12.0	14.0	2.0	3.0	3.0
TLDOA0555	55.5	70.0	22.0	52.5	73.8	73.1	55.5	10.0	11.5	2.4	5.0	3.0
TLDOA0560	56.0	70.0	25.0	53.0	76.0	75.2	66.0	12.0	14.0	2.0	3.0	3.0
TLDOA0580	58.0	74.0	27.0	55.0	79.4	78.6	67.0	13.5	15.5	2.0	3.0	3.0
TLDOA0600 <sup>1)</sup>	60.0	74.0	20.6	57.0	78.4	77.4	70.0	9.0	11.0	1.9	2.5	3.0
TLDOA0610	61.0	73.0	17.6	58.0	75.8	75.5	68.5	8.0	9.5	1.4	1.5	2.0
TLDOA0635	63.5	82.5	31.8	60.5	86.8	85.9	74.0	15.0	17.0	3.0	2.5	3.0
TLDOA0640 <sup>1)</sup>	64.0	78.0	25.0	61.0	84.6	83.6	74.0	12.5	14.5	2.0	3.0	3.0
TLDOA0660	66.0	85.0	28.0	63.0	90.0	89.2	78.0	14.0	16.0	2.0	3.0	3.0
TLDOA0690 <sup>1)</sup>	69.0	84.0	24.0	66.0	89.6	88.6	78.5	11.0	13.0	1.9	3.0	3.0
TLDOA0710 <sup>1)</sup>	71.0	90.0	29.0	68.0	95.5	94.7	84.0	13.5	15.5	2.0	3.0	3.0
TLDOA0730	73.0	92.0	31.8	70.0	96.2	95.4	84.0	15.0	17.0	3.0	2.5	3.0
TLDOA0740	74.0	86.6	22.0	71.0	91.4	90.7	80.0	9.5	11.5	2.0	3.0	3.0
TLDOA0800	80.5	99.5	29.0	77.0	105.0	104.2	92.0	14.5	16.5	2.0	3.0	3.0
TLDOA0810	81.0	98.0	28.0	78.0	102.3	101.1	91.0	12.5	14.5	2.8	5.0	

Missing values on request <sup>1)</sup>  $\alpha=12^\circ$  <sup>2)</sup>  $\alpha=15^\circ$



TSS Part No.	D <sub>i</sub>	D <sub>a</sub>	L	d <sub>max.</sub>	D±0.1	D <sub>1</sub> ±0.1	D <sub>3</sub>	L <sub>1</sub>	L <sub>2</sub> min.	L <sub>5</sub>	r	S
TLDOA0820	82.0	98.0	22.0	79.0	102.3	101.3	91.0	9.0	11.0	2.8	5.0	3.0
TLDOA0900	90.5	109.0	32.0	87.0	113.6	112.9	101.0	15.0	17.0	3.0	2.5	3.0
TLDOA0920	92.0	109.0	22.0	89.0	113.8	113.0	105.0	9.5	11.5	1.8	2.5	3.0
TLDOA0940	94.0	106.5	22.0	91.0	111.6	110.8	102.0	9.5	11.5	2.0	3.0	3.0
TLDOB0950 <sup>1)</sup>	95.0	114.0	31.0	92.0	120.0	119.2	107.0	15.0	17.0	2.5	3.0	3.0
TLDOA0990	99.0	120.0	28.0	96.0	123.5	122.5	112.0	12.5	14.5	2.8	5.0	3.0
TLDOA1000	100.0	119.0	31.8	97.0	123.2	122.4	111.0	14.5	16.5	2.5	2.5	3.0
TLDOB1000	100.0	120.0	29.4	97.0	125.0	124.2	111.0	14.0	16.0	2.9	3.0	3.0
TLDOA1020	102.0	122.0	32.0	99.0	127.2	126.2	115.0	15.5	17.5	2.5	3.0	3.0
TLDOB1040	104.0	116.7	21.2	101.0	121.0	120.2	107.0	9.5	11.5	2.0	3.0	3.0
TLDOC1040	104.0	121.0	22.0	101.0	125.5	125.1	117.5	9.5	11.5	2.0	3.0	3.0
TLDOB1100 <sup>1)</sup>	109.0	127.0	32.0	106.0	133.0	132.0	121.0	15.0	17.0	2.5	3.0	3.0
TLDOA1090	109.0	132.0	32.0	106.0	136.6	135.6	124.0	15.5	17.5	2.5	3.0	3.0
TLDOA1150	115.0	137.0	31.0	112.0	141.8	140.8	130.0	14.5	16.5	2.5	3.0	3.0
TLDOA1240	124.0	141.0	22.0	121.0	145.8	145.0	136.0	9.5	11.5	2.0	3.0	3.0
TLDOA1270	127.0	146.0	31.8	123.0	150.2	149.4	138.0	14.0	16.0	2.5	2.5	4.0
TLDOD1300	130.0	152.0	38.0	127.0	159.0	158.0	144.0	18.5	20.5	2.5	3.0	3.0
TLDOB1430	143.0	157.0	25.0	140.0	159.7	158.9	152.0	11.5	13.5	2.5	2.8	4.0
TLDOA1460	146.0	168.0	38.0	143.0	177.0	176.0	159.0	18.0	20.0	2.5	3.0	4.0
TLDOC1500	150.0	172.0	40.0	147.0	179.0	178.0	165.0	18.0	20.0	2.5	3.0	4.0
TLDOB1530	154.0	168.0	25.0	151.0	171.0	170.2	164.0	11.5	13.5	2.5	2.8	4.0
TLDOB1630	163.0	191.0	38.0	160.0	196.4	195.5	179.0	18.0	20.0	3.1	6.4	4.0
TLDOA1910	191.0	210.0	28.0	187.0	214.0	213.0	203.0	12.5	14.5	2.8	5.0	3.0
TLDOA1920	192.0	215.0	33.0	189.0	220.8	219.8	207.0	16.5	18.5	3.0	4.0	4.0
TLDOA2090	209.0	234.0	42.0	206.0	242.6	241.6	224.0	19.5	21.5	3.0	4.0	4.0
TLDOA2200	220.0	239.5	31.8	217.0	244.0	243.0	232.0	14.5	16.5	2.8	5.0	3.0
TLDOA2240	223.5	252.0	38.0	220.0	256.6	255.7	238.0	18.0	20.0	3.1	6.4	3.0
TLDOA2400	240.0	262.8	38.0	237.0	273.5	272.5	257.0	19.0	21.0	3.0	4.0	4.0
TLDOA2500	250.0	276.0	41.0	247.0	284.6	283.6	266.0	20.5	22.5	3.0	4.0	4.0
TLDOA2650	265.0	293.0	38.0	262.0	298.0	297.0	280.0	19.0	21.0	3.0	6.4	4.0
TLDOA2750	275.0	303.0	38.0	271.0	308.0	307.0	290.0	18.0	20.5	3.1	4.0	
TLDOB3000	300.0	328.0	39.0	297.0	333.0	332.0	315.0	19.5	22.0	3.0	4.0	4.0
TLDOA3180	318.0	341.0	38.0	315.0	351.6	350.7	335.0	19.0	20.5	3.0	6.4	
TLDOA3185	318.5	346.5	38.0	315.0	351.6	350.6	335.0	19.0	21.5	3.0	6.4	
TLDOA3400	340.0	368.0	38.0	333.0	375.7	374.8	368.0	19.6	22.1	3.1	4.0	2.0
TLDOB3665	366.5	391.0	38.0	363.0	399.5	398.5	382.0	18.5	21.0	3.0	4.0	4.0
TLDOA3665	366.5	394.5	38.0	363.0	399.5	398.6	382.0	18.5	21.0	3.0	6.4	4.0
TLDOA3870	387.0	415.0	38.0	384.0	419.5	418.5	400.0	18.0	20.5	3.0	4.0	3.0
TLDOA4290	429.0	457.0	38.0	426.0	463.5	462.5	444.0	18.0	20.5	3.0	4.0	3.0

Missing values on request <sup>1)</sup> α=12° <sup>2)</sup> α=15°



## Mechanical Face Seals

### Ordering Example

Mechanical Face Seal Type DO in Cast Iron

Inside diameter Di = 115.0 mm

Materials: Seal rings of Cast Iron  
O-Rings of NBR

TSS Article No.	TLDOA1150	-	2FP00
TSS Part No.			
Inside Ø x 10			
Quality Index (Standard)			
Material No.			

Dimensions and Part Number see Table VI, page 12.  
Materials see page 4.



## ■ Installation Recommendations for Type DF Bearing Steel

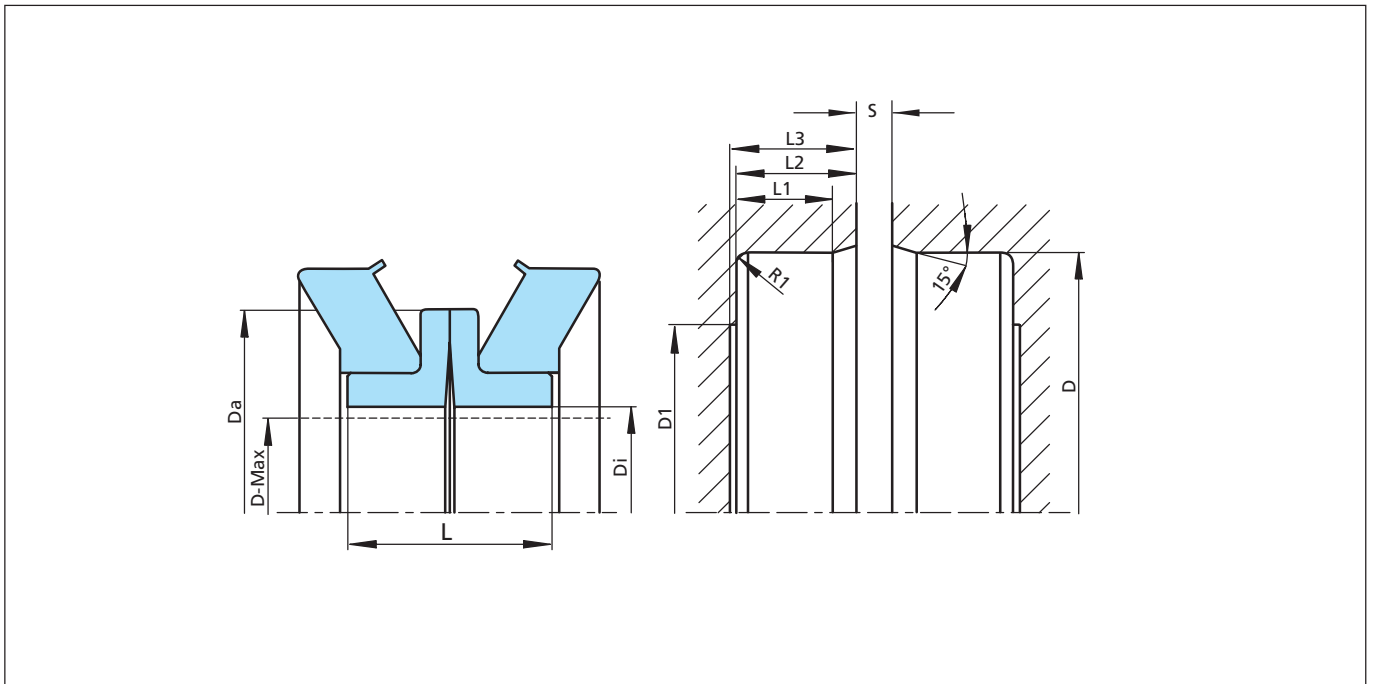

Figure 11 Installation Drawing

**Table VII Installation Dimensions**

TSS Part No.	GNL	$D_i$	$D_a$	L	$d_{max.}$	D	$D_1$	$L_1$	$L_2$	$L_3$	S
TL DFA0420	0627	42.0	59.0	20.0	38.0	65.0	53.0	8.0	10.0	10.5	3.0
TL DFA0470	5301	47.0	62.0	20.0	44.0	70.0	58.0	8.0	10.0	11.0	3.0
TL DFA0505	6161	50.5	65.0	19.0	46.0	76.2	63.0	8.0	10.0	11.0	2.5
TL DFA0540	0870	54.0	73.0	22.0	50.0	80.0	67.0	10.0	11.5	12.0	3.0
TL DFA0585	2011	58.5	73.0	19.0	54.0	82.5	65.0	8.0	10.0	11.0	3.0
TL DFA0586	0351	58.6	80.0	19.6	57.0	84.0	71.0	7.5	9.0	9.5	3.0
TL DFA0635	5471	63.5	81.0	19.0	59.5	87.8	71.0	8.0	9.0	9.5	3.0
TL DFA0670	6361	67.0	86.2	20.0	64.0	95.4	82.0	8.0	10.0	11.0	3.0
TL DFB0670	0926	67.0	87.0	25.0	64.0	95.0	81.0	11.0	12.5	13.0	4.0
TL DFC0670	6391	67.0	91.7	20.0	64.0	95.4	82.0	8.0	10.0	11.0	3.0
TL DFA0680	0691	68.0	86.2	20.0	64.0	95.6	82.0	8.0	10.0	11.0	3.5
TL DFA0738	6461	73.8	92.8	20.0	70.0	102.2	88.0	8.0	10.0	11.0	3.0
TL DFA0740	6571	74.0	99.0	20.0	70.0	102.2	88.0	8.0	10.0	11.0	3.0
TL DFA0770	1002	77.0	97.0	25.0	74.0	105.0	87.0	11.0	12.5	13.5	4.0
TL DFA0817	5311	81.7	101.5	20.0	70.0	110.2	96.0	8.0	10.0	11.0	3.0
TL DFA0825	2001	82.5	100.0	22.0	78.0	114.3	97.0	9.0	11.0	12.0	3.5
TL DFA0875	0331	87.5	109.0	17.5	83.0	113.0	100.0	7.0	8.5	9.5	3.0
TL DFB0875	0398	87.5	111.5	19.0	85.0	115.8	102.0	8.5	10.0	11.0	3.0
TL DFA0920	0751	92.0	113.0	24.0	88.0	125.8	109.0	10.0	12.5	13.0	3.0



## Mechanical Face Seals

TSS Part No.	GNL	D <sub>i</sub>	D <sub>a</sub>	L	d <sub>max.</sub>	D	D <sub>1</sub>	L <sub>1</sub>	L <sub>2</sub>	L <sub>3</sub>	S
TL DFA0940	6661	94.0	112.5	24.0	90.0	125.8	109.0	10.0	12.5	13.0	3.0
TL DFA0990	0341	99.0	120.0	17.5	95.0	124.0	110.0	7.0	8.5	9.5	3.0
TL DFB0990	0399	99.0	123.0	19.0	95.0	127.3	113.0	7.0	10.0	11.0	3.0
TL DFA1040	0911	104.0	126.0	24.0	100.0	135.0	114.0	10.0	12.0	13.0	4.0
TL DFB1050	2081	105.0	124.0	24.4	101.0	134.9	125.0	12.0	13.3	14.5	3.0
TL DFA1140	2071	114.0	133.2	26.0	110.0	147.9	130.0	10.5	12.0	13.0	4.0
TL DFB1140	0666	114.0	138.0	26.0	110.0	148.0	126.0	10.0	12.0	13.0	4.0
TL DFA1240	5371	124.0	144.0	32.0	119.0	162.5	141.5	17.0	18.5	20.5	3.0
TL DFA1330	1311	133.0	156.0	28.0	128.0	171.5	151.0	11.0	13.0	14.0	6.5
TL DFA1485	5001	148.5	168.0	32.4	143.0	184.1	164.0	15.0	16.5	17.5	5.0
TL DFA1500	0885	150.0	175.0	30.0	145.0	190.0	170.0	13.0	15.0	15.5	5.0
TL DFA1540	2021	154.0	180.0	36.0	149.0	194.0	174.0	17.0	18.4	20.0	4.5
TL DFA1580	0791	158.0	180.0	18.0	153.0	190.0	174.0	7.0	8.0	10.0	6.0
TL DFA1690	2041	169.0	195.0	33.0	164.0	206.2	191.5	14.0	15.1	18.4	5.0
TL DFA1777	5931	177.7	207.0	29.0	173.0	218.9	197.0	15.0	16.6	17.5	
TL DFA1930	6671	193.0	214.3	31.0	187.0	238.9	215.0	18.0	19.4	20.4	3.0
TL DFA1940	5941	194.0	214.5	31.0	188.0	238.8	214.0	19.0	20.1	21.0	
TL DFA1980	0937	198.0	224.0	35.0	195.0	245.0	223.0	15.0	17.0	17.5	6.0
TL DFA2280	2051	228.0	260.5	41.0	221.0	277.1	247.5	22.0	23.5	24.5	4.0
TL DFA2330	1023	233.0	259.0	35.0	225.0	280.0	250.0	15.0	17.0	18.0	6.0
TL DFA2415	6481	241.5	273.5	36.0	235.0	279.4	260.6	16.5	17.5	20.0	2.0
TL DFA2750	5951	275.0	303.0	36.0	270.0	309.4	290.0	16.5	17.5	20.0	2.0
TL DFA2830	5901	283.0	305.0	42.0	278.0	329.4	307.0	17.0	18.5	22.1	3.0
TL DFA3200	5921	320.0	352.5	40.0	312.0	365.1	343.0	18.5	20.0	21.5	2.0
TL DFA3550	2031	355.0	392.0	39.6	345.0	401.7	380.0	21.5	23.0	24.0	1.8
TL DFA4420	6561	442.0	470.0	41.0	435.0	488.7	467.0	17.0	18.4	22.0	2.5
TL DFA4920	5911	492.0	530.0	43.0	480.0	546.1	532.0	18.4	19.9	24.4	2.0

### Ordering Example

Mechanical Face Seal Type DF in Bearing Steel

Inside diameter: Di = 150 mm

Material: Sealing ring of Bearing Steel  
Square ring of NBR

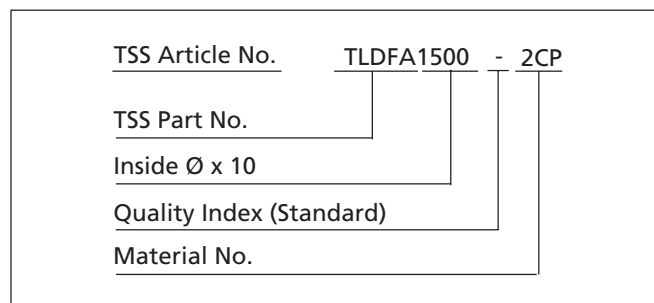

Dimensions and Part Number see Table VII, page 15.  
Materials see page 4.



**Contact your local marketing company for further information:**

<b>Europe</b>	<b>Telephone</b>	<b>Americas</b>	<b>Telephone</b>
<b>AUSTRIA - Vienna</b> <small>(ALBANIA, BOSNIA AND HERZEGOVINA, MACEDONIA, SERBIA AND MONTENEGRO, SLOVENIA)</small>	+43 (0) 1 406 47 33	<b>AMERICAS - REGIONAL</b>	+1 260 749 9631
<b>BELGIUM - Dion-Valmont</b> <small>(LUXEMBOURG)</small>	+32 (0) 10 22 57 50	<b>BRAZIL - São Paulo</b>	+55 11 3372 4500
<b>BULGARIA - Sofia</b> <small>(ROMANIA)</small>	+359 (0)2 969 95 99	<b>CANADA - Etobicoke, ON</b>	+1 416 213 9444
<b>CROATIA - Zagreb</b>	+385 (0) 1 24 56 387	<b>MEXICO - Mexico City</b>	+52 55 57 19 50 05
<b>CZECH REPUBLIC - Rakovnik</b> <small>(SLOVAKIA)</small>	+420 313 529 111	<b>USA, East - Conshohocken, PA</b>	+1 610 828 3209
<b>DENMARK - Hillerød</b>	+45 48 22 80 80	<b>USA, Great Lakes - Fort Wayne, IN</b>	+1 260 482 4050
<b>FINLAND - Vantaa</b> <small>(ESTONIA, LATVIA)</small>	+358 (0) 207 12 13 50	<b>USA, Midwest - Lombard, IL</b>	+1 630 268 9915
<b>FRANCE - Maisons-Laffitte</b>	+33 (0) 1 30 86 56 00	<b>USA, Mountain - Broomfield, CO</b>	+1 303 469 1357
<b>GERMANY - Stuttgart</b>	+49 (0) 711 7864 0	<b>USA, Northern California - Fresno, CA</b>	+1 559 449 6070
<b>GREECE</b>	+41 (0) 21 631 41 11	<b>USA, Northwest - Portland, OR</b>	+1 503 595 6565
<b>HUNGARY - Budaörs</b>	+36 (0) 23 50 21 21	<b>USA, South - N. Charleston, SC</b>	+1 843 747 7656
<b>ITALY - Livorno</b>	+39 0586 22 6111	<b>USA, Southwest - Houston, TX</b>	+1 713 461 3495
<b>THE NETHERLANDS - Barendrecht</b>	+31 (0) 10 29 22 111	<b>USA, West - Torrance, CA</b>	+1 310 371 1025
<b>NORWAY - Oslo</b>	+47 22 64 60 80		
<b>POLAND - Warsaw</b> <small>(LITHUANIA, UKRAINE, BELARUS)</small>	+48 (0) 22 863 30 11	<b>Asia Pacific</b>	<b>Telephone</b>
<b>RUSSIA - Moscow</b>	+7 495 982 39 21	<b>ASIA PACIFIC REGIONAL</b>	+65 6 577 1778
<b>SPAIN - Madrid</b> <small>(PORTUGAL)</small>	+34 (0) 91 71057 30	<b>CHINA - Hong Kong</b>	+852 2366 9165
<b>SWEDEN - Jönköping</b>	+46 (0) 36 34 15 00	<b>CHINA - Shanghai</b>	+86 (0) 21 6145 1830
<b>SWITZERLAND - Crissier</b>	+41 (0) 21 631 41 11	<b>INDIA - Bangalore</b>	+91 (0) 80 2245 5157
<b>TURKEY</b>	+41 (0) 21 631 41 11	<b>JAPAN - Tokyo</b>	+81 (0) 3 5633 8008
<b>UNITED KINGDOM - Solihull</b> <small>(EIRE)</small>	+44 (0) 121 744 1221	<b>KOREA - Anyang</b>	+82 (0) 31 386 3283
<b>AFRICA REGIONAL</b>	+41 (0) 21 631 41 11	<b>MALAYSIA - Kuala Lumpur</b>	+60 (0) 3 9059 6388
<b>MIDDLE EAST REGIONAL</b>	+41 (0) 21 631 41 11	<b>TAIWAN - Taichung</b>	+886 4 2382 8886
		<b>THAILAND - Bangkok</b>	+66 (0) 2732-2861
		<b>SINGAPORE</b>	
		<b>and all other countries in Asia</b>	+65 6 577 1778

[www.tss.trelleborg.com](http://www.tss.trelleborg.com)

